

# Power Grid Geomagnetic Disturbance (GMD) Modeling with Transformer Neutral Blocking and Live Grid Testing Results

T.J. Overbye, University of Illinois at Urbana-Champaign, Illinois, e-mail:  
[overbye@illinois.edu](mailto:overbye@illinois.edu)

F.R. Faxvog, W. Jensen, G. Fuchs, G. Nordling, D.B. Jackson, B.Groh, N. Ruehl, A.P.  
Vitols, T. L. Volkmann, Emprimus LLC, Minneapolis, MN, e-mail:

[ffaxvog@emprimus.com](mailto:ffaxvog@emprimus.com)

D. Fromme, G. Edmiston, A. Walker, SARA Inc., Colo. Springs, CO

M.R. Rooney, Defense Threat Reduction Agency (DTRA), Fort Belvoir, VA

## **Abstract**

This paper provides background material for a presentation describes that the modeling of geomagnetic disturbances (GMDs) in the power flow and the impact of GIC neutral block devices. GMDs cause quasi-dc, geomagnetically induced currents (GICs) in the transformers and transmission lines, which in turn cause saturation of the high voltage transformers, greatly increasing their reactive power consumption which can result in grid voltage collapse. GICs can be calculated using standard power flow modeling parameters such as line resistance, augmented with several GIC specific fields including substation geographic coordinates and grounding resistance, transformer configuration, and transformer coil winding resistances. Additionally, transformer saturation also gives rise to significant harmonic generation that can cause control system interferences. Finally, new design and production developments for a transformer GIC neutral blocking system, SolidGround™, will be described. A summary of live power grid operation test results at the Idaho National Laboratory (INL) using this neutral blocking system with simulated GIC currents will be presented.

## **Introduction**

Geomagnetic disturbances (GMDs) have the potential to affect the power grid by impacting the earth's magnetic field, which in turn can induce quasi-dc electric fields in the earth (with frequencies usually much below 1 Hz). These electric fields then cause geomagnetically induced currents (GICs) to flow in the high voltage grid that can cause half-cycle saturation in the power transformers, resulting in increased transformer reactive power losses. This paper provides a brief background of the power flow modeling of GICs, and then provides coverage of a transformer neutral blocking system design.

This SolidGround™ system provides a normal metallic grounding path for transformers through two high current breakers. When a Geomagnetic Current (GIC) or EMP E3 current is detected by the system electronics, the grounding breaker assembly is opened and a parallel connected capacitor bank then provides the AC ground path for the transformer neutral but at the same time blocks the quasi-DC GIC current. The presence of a GMD or EMP E3 event is provided by the detection of either the quasi-DC

GIC current in the transformer neutral or harmonics on a phase which are generated when GIC drives the transformer into saturation. The operation is automatic with no manual intervention. Since GMD events are rather infrequent, the system will be in the normal grounding mode most of the time i.e. through the metallic contacts in the breakers. So on average, using suitable detection level settings, the SolidGround™ system will only be in the GMD protection mode ( i.e. the neutral DC current blocking mode) for only a few hours on average every fourteen months. Live grid experiments using this neutral blocking system were carried out at the Idaho National Laboratories in September of 2012. The results of these experiments are also summarized in this paper.

### Overview of GIC Power Flow Modeling

The inclusion of the impact of GICs in the power flow was first described in [1], with later consideration for large system studies in [2], [3]. Some considerations of GIC on power system voltage stability are presented in [4]. In order to include the impact of GMDs in the power flow, first the quasi-dc GICs are calculated, by modeling the GMD-induced electric field variation in the power grid as dc voltage sources in series with the transmission lines [5]. Using this approach to calculate the GMD-induced voltages on each line the electric field is just integrated over the length of the line.

The GICs in the system are then determined by solving

$$\mathbf{V} = \mathbf{G}^{-1}\mathbf{I} \quad (1)$$

where vector  $\mathbf{I}$  models the impact of the GMD-induced dc line voltages as Norton equivalent dc current injections.  $\mathbf{G}$  is a symmetric matrix similar in form to the power system bus admittance matrix, except 1) it is a real matrix with just conductance values, 2) conductance values are determined by the parallel combination of the three individual phase resistances, 3)  $\mathbf{G}$  is augmented to include the substation neutral buses and substation grounding resistance values, 4) transmission lines with series capacitive compensation are omitted since series capacitors block dc flow, and 5) transformers are modeled with their winding resistance to the substation neutral and in the case of autotransformers, both the series and common windings are represented. For large systems,  $\mathbf{G}$  is quite sparse and hence (1) can be solved with computational effort equivalent to a single power flow iteration. When solved, the voltage vector  $\mathbf{V}$  contains entries for the substation neutral dc voltages and the bus dc voltages.

Next, the GIC-related transformer reactive power losses are determined to model into the power flow. A linear function can be used to map the GICs to the losses [6], with [7] making the observation that these losses vary linearly with terminal voltage. Hence the losses could be written as

$$Q_{Loss} = V_{pu} K I_{GIC} \quad (2)$$

where, for each transformer,  $V_{pu}$  is the pu voltage,  $K$  has units of Mvars/amp,  $I_{GIC}$  is an “effective” value that depends on the type of transformer, and  $Q_{Loss}$  is the transformer’s GIC-related reactive power loss in Mvar. Using this approach, the power flow can be solved with the impact of GICs included. Over the last year or so this approach has been integrated into commercial software packages, allowing power system planning engineers to study the impact of GICs on their systems.

Also, new GIC power analysis functionality is under development, including the modeling of transformer neutral current blocking devices and algorithms to determine their optimal placement. Such devices offer the potential to reduce the impact of GMDs on power system operations. Additional details on such blocking devices are presented in the next section.

### **Neutral Blocking System and Live Power Grid Results**

A photo of the SolidGround™ transformer neutral blocking system is shown in figure 1. The system primarily consists of commercially available components that are routinely used in the power industry. The concept was studied using PSCAD software before fabricating the system was constructed [8]. A complete description of the system was recently presented at the IEEE PES Conference held in Nova Scotia, Canada, August 22-23, 2013 [9]. A block diagram of the system is shown in figure 2. It consists of two breakers in series with a shunt resistor to provide the grounding of a transformer while in the non-protective GIC mode of operation. Using conservative trigger settings for the quasi-DC GIC current and harmonic levels, it is expected that the system will be in the non-protective GIC mode 99.9% of the time.

A signal from the one (1) milli-ohm shunt resistor is used to detect the presences of a quasi-DC current. This signal or the detection of harmonics on one of the phases is then used to trigger the system into its protection mode. The trigger signal from the electronics opens the DC breaker which in-turn opens the AC breaker. Immediately after this step the DC break is closed but the AC breaker remains open while in the GIC protection mode. A DC breaker is used to ensure the opening of the breaker assembly. And an AC breaker is used to protect the DC breaker from any high voltages.

Once in the protective mode, the 2,650  $\mu$ F capacitor bank blocks the quasi-DC GIC current but provides a one ohm reactance AC grounding impedance for the transformer neutral. A one ohm power resistor is also used in series with the capacitor bank to both reduce AC voltages across the capacitors and to provide damping of any unwanted resonances that might appear. It is expected that using conservative trigger level settings that the system will only be in the protective mode less than 0.1% of the time (i.e. less than one hour on average ever 14 months when moderately large GMD events are experienced).

If a ground fault occurs while the system is in the non-protective mode, the breakers will conduct the current until relays trip the line. In the case that a ground fault should occur while in the protective mode the MOV shown in the figure will conduct the first several cycles. The current transformer (CT) shown below the MOV is used to sense this ground current and trigger the AC breaker to close. A lock-put relay is used to then keep the breaker assembly closed until the MOV is replaced. A newer version of the system will use a Thyristor in place of the MOV to avoid the need for replacement of any components. Finally, a spark gap is available as a final layer of protection in that all other paths in the system should be come open circuited.

The system first underwent ground fault testing at the KEMA-Powertest facility in Chalfont, PA. The results of these tests are summarized in a separate paper [9]. Following these tests, the system was shipped to the Idaho National Laboratory in Idaho Falls, ID. The system was connected into their 138 kV, 61mile loop which was connected to the western interconnect. Two grounded wye-delta transformers (3.75 MVA and 15 MVA) at the site were used in these experiments. Two primary test scenarios were conducted. The first was global in which both transformer neutrals were connected to the SolidGround™

system. In the second scenario neutral blocking was applied to only one of the transformers. A complete report on the findings will soon be published by the Defense Threat Reduction Agency (DTRA) [10].

The transformers were subjected to DC currents from a battery pack which consisted of 61, 12 volt batteries. As a safety precaution these currents were limited to 8 seconds. In the first scenario these DC currents applied to both transformer neutrals. The graphs in figure 4 show that the injected DC currents reach a saturation level after about 7 seconds. The four saturated current levels were about 33, 62, 96 and 123 amps. These initial tests were conducted with no neutral blocking applied.

Figure 4 also shows the results under this scenario when the SolidGround™ system was connected to the transformer neutrals. Initially the electronics triggering delay time was set at 1.7 seconds to avoid any false positive detection signals. When the electronics detected the injected DC current, the system switched into its protective mode and the DC current was rapidly decreased to zero as was expected. Some ringing was observed when blocking occurred which was in good agreement with the PSCAD simulation studies [3]. In a further run the electronics fixed delay was set to 0.7 seconds and the results are again shown in the figure.

In these experiments the DC trigger level was set at 6 amps and the Total Harmonic Distortion (THD) trigger level set at 2%. In every case during these tests the system electronics triggered on the DC current level not the THD signal. In future applications the fixed delay time can be adjusted to as low as a few tens of milli-seconds especially for the detection of very fast onset GIC or EMP E3 events.

## **Summary**

GMD modeling both has a long history but is also an area of active research. With GMD analysis now integrated into commercial power flow software packages, this type of analysis is moving into the realm of power system planning and operations. An area of active consideration is the inclusion of GIC blocking devices. A GMD / EMP E3 transformer and grid protection system, SolidGround™, was designed, fabricated and extensively tested. The system protects HV and EHV transformers and static VAR compensators against geomagnetic currents (GIC) as well as EMP E3 induced currents. The system was shown to reliably and effectively block GIC currents when detected. The grounding system design is fail-safe with multiple parallel paths to earth ground for AC currents. Live power grid experiments showed the system operated reliably and in agreement with earlier PSCAD simulations. The electrical components in the system are all accepted commercial items with many hours of field service experience. Factory assembled systems are now available from a large worldwide utility supplier.

## **Acknowledgements**

The University of Illinois work presented here was partially funded by EPRI and by the US Department of Energy through “The Future Grid to Enable Sustainable Energy Systems: An Initiative of the Power Systems Engineering Research Center (PSERC). Their support is gratefully acknowledged. The Emprimus authors would like to thank George E. Anderson of Emprimus LLC for his continual encouragement and critical reviews of the project. The authors would also like to thank the following people for their encouragement and helpful comments during the development of the Emprimus Solid Ground neutral blocking system; George Baker Professor Emeritus, James Madison University, Russell

Neal and Bill Chiu of So. Calif. Edison, Frank Lembo and Bob Sanchez of Con Edison Corp., Steven Naumann of Exelon Corp., and David Wojtczak of American Transmission Corp.

## References

- [1] V.D. Albertson, J.G. Kappenman, N. Mohan, and G.A. Skarbakka, "Load-Flow Studies in the Presence of Geomagnetically-Induced Currents," *IEEE Trans. on Power Apparatus and Systems*, PAS-100, pp. 594-606, Feb. 1981.
- [2] J. Kappenman, "Geomagnetic Storms and Their Impacts on the U.S. Power Grid," Metatech Corporation Report Meta-R-319, Jan. 2010.
- [3] T.J. Overbye, T.R. Hutchins, K. Shetye, J. Weber, S. Dahman, "Integration of Geomagnetic Disturbance Modeling into the Power Flow: A Methodology for Large-Scale System Studies," *Proc. 2012 North American Power Symposium*, September 2012, Champaign, IL.
- [4] T.J. Overbye, K.S. Shetye, Y.Z. Hughes, J.D. Weber, "Preliminary Consideration of Voltage Stability Impacts of Geomagnetically Induced Currents," *Proc. 2013 IEEE PES General Meeting*, Vancouver, BC, July 2013.
- [5] D.H. Boteler, R.J. Pirjola, "Modeling Geomagnetically Induced Currents Produced by Realistic and Uniform Electric Fields," *Proc. IEEE Trans. on Power Delivery*, vol. 13, Oct. 1998, pp. 1303-1308.
- [6] X. Dong, Y. Liu, J.G. Kappenman, "Comparative Analysis of Exciting Current Harmonics and Reactive Power Consumption from GIC Saturated Transformers," *Proc. IEEE 2001 Winter Meeting*, Columbus, OH, pp. 318-322, Jan. 2001.
- [7] R.A. Walling, A.H. Khan, "Characteristics of Transformer Exciting Current During Geomagnetic Disturbances", *IEEE Transactions on Power Delivery*, Vol. 6, No. 4, October 1991.
- [8] A.D. Rajapakse, et.al. "Power Grid Stability Protection against GIC Using a Capacitive Grounded Circuit" 2012 IEEE PES T&D Conf., Orlando FL, May 7-10, 2012
- [9] F.R. Faxvog et.al. Power Grid Protection against Geomagnetic Disturbances (GMD)
- [10] D. Fromme, G. Edmiston, A. Walker, M. Rooney, MHD-E3 Transmission Level Power Grid Test Report Part III – Phase IVB Emprimus SolidGround™ Evaluation, Defense Threat Reduction Agency, Fort Belvoir, VA 22060-2601, September, 2013

## Figures



Figure 1 - Photo of the SolidGround™ Transformer Neutral Blocking System

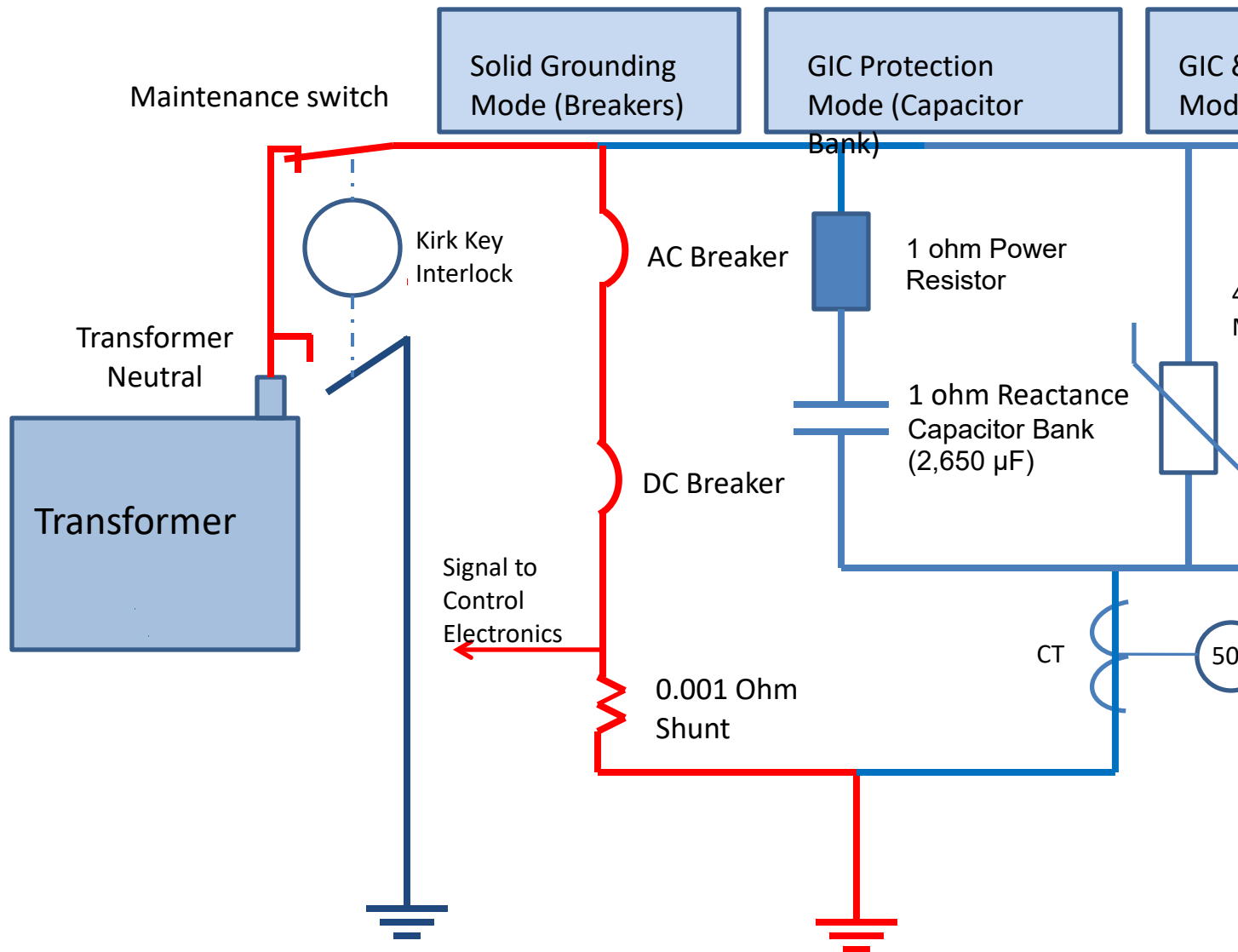

Figure 2 - Diagram of the SolidGround™ Transformer Neutral Blocking System

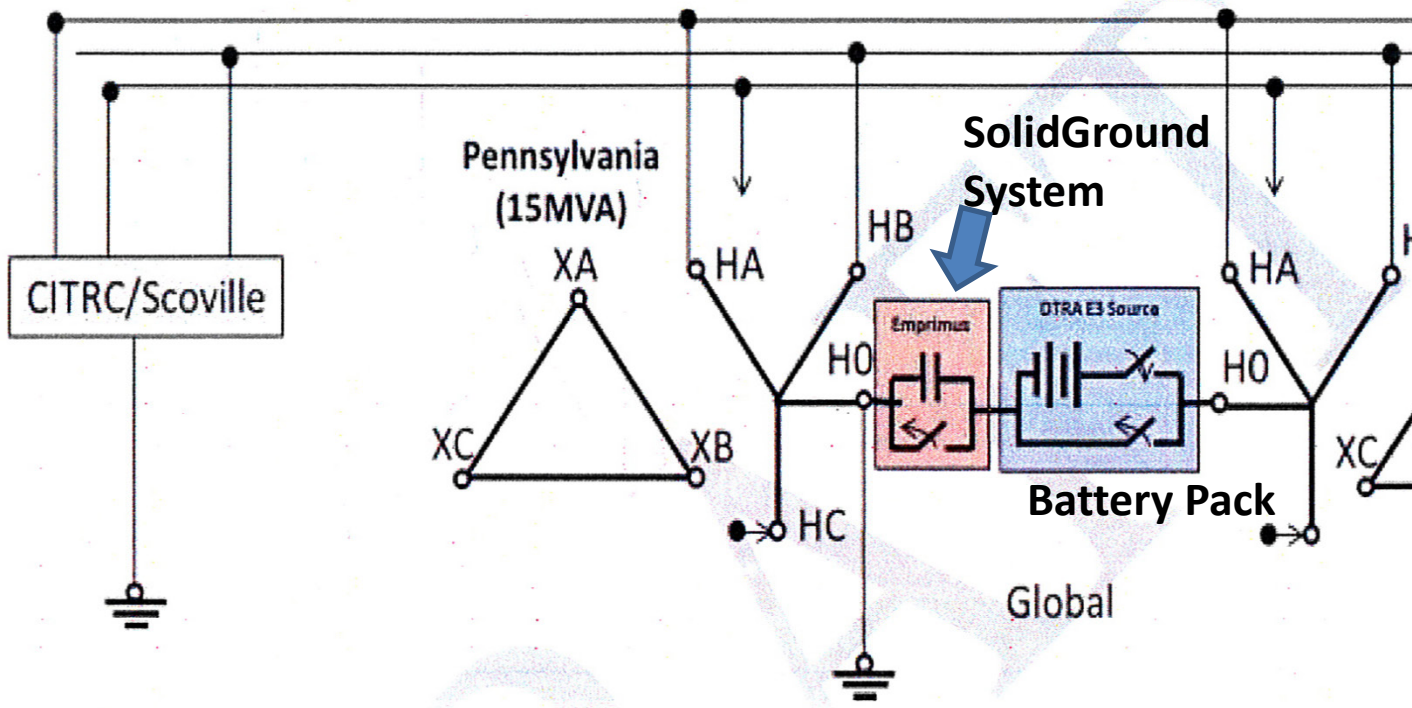

Figure 3 - Idaho National Laboratory Experimental Configuration for testing the Neutral Blocking System



